



1.000 - 10.000 l/h

Typical applications

Plating - Rinsing - Filtration

Features

- Immersion length series
D90 270mm / D120 400mm
- Environmentally safe in-tank installation
- Free turning shaft - no seal
- Self priming - can run dry
- Full length motor shaft
- Outlet sockets available in PP, PVDF and CPVC

Options

- Suction extension pipe
- Hose connection

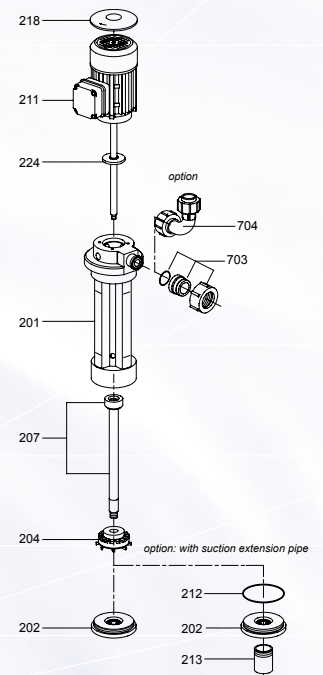

D123

D92

Vertical pumps series D90 / D120 - PP/PVDF

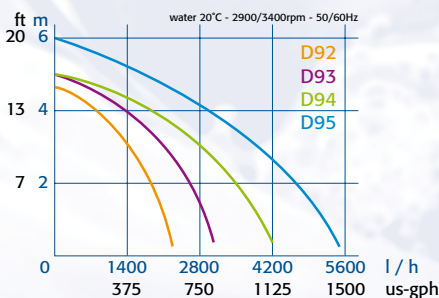

Type	Material	kW	HP	Out(d/DN)
D92		0,12*	1/6	
D93	PP/PVDF	0,18*	1/4	25/20
D94		0,25*	1/3	
D95		0,37*	1/2	

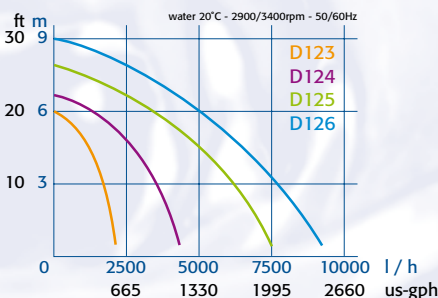

Type	Material	kW	HP	Out(d/DN)
D123		0,18*	1/4	
D124	PP/PVDF	0,25*	1/3	32/25
D125		0,37*	1/2	
D126		0,55	3/4	

i www.hendor.com

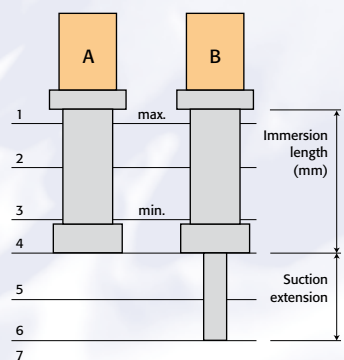

* For 3-phase motors < 220V the indicated motor will be one size bigger.